

XB-56 Manual

WARNING

Safety precautions:

- Always be sure of your target and beyond.
- Misuse or careless handling of this product can cause serious injury or even death.
- This is not a toy. It is a high poundage crossbow capable of shooting projectiles over 200 yards. It is intended for use by persons 18 years of age or older.
- Only shoot with proper bolts that have a minimum grain weight of 400 grains.
- Discontinue use if the crossbow becomes damaged.
- It is highly recommended to use eye protection while using this product.
- Keep your fingers clear of the travel path of strings and or cables.

CAUTION:

- Please read and follow all instructions carefully.
- It is recommended that a Qualified Archery Pro Shop set up the crossbow.
- The crossbow should be used in accordance with all applicable laws.
- It is recommended to lube the rail every 10 to 15 shots.
- Replace strings and or cables every year, or at the first sign of wear or fraying.

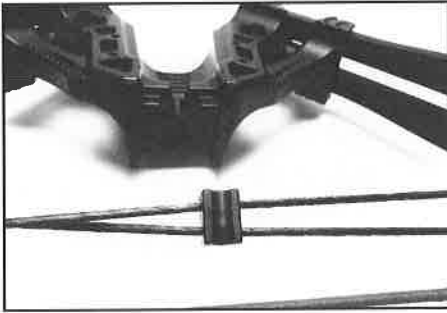

1. Be sure the cable slide is properly attached to the cables.
The gap on the lower side is larger than the upper side.

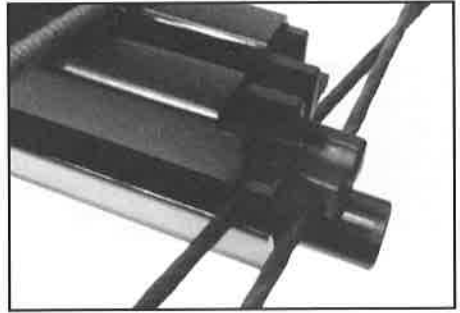

2. Slide the cable slide into the crossbow riser.

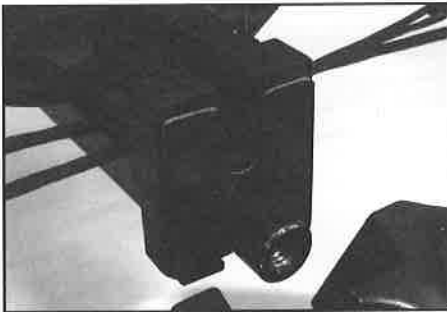

3. Insert the joint cap onto the crossbow barrel.



4. Slide the barrel onto the riser.

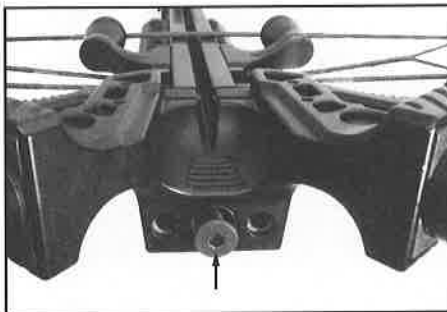

5. Install and tighten the Riser bolt firmly.

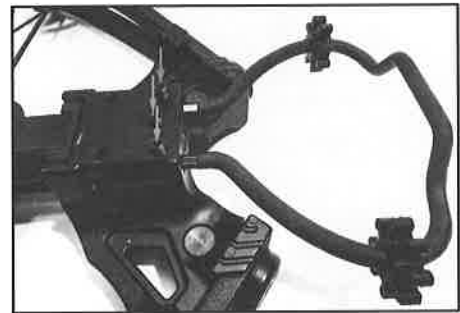

6. Attach the stirrup onto the riser by using 3 screws (2 long and 1 short screw).

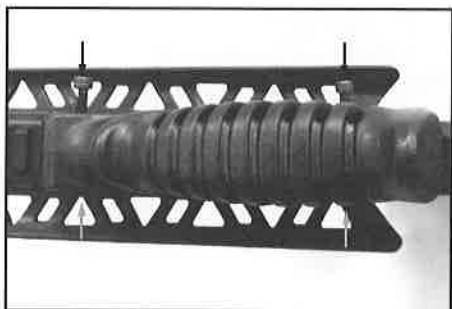

7. Adjust the grip under the crossbow barrel.
a: Loose out the 2 screws on the grip.

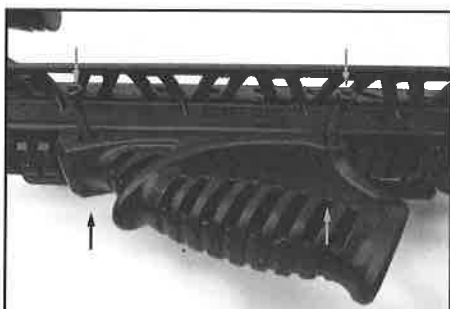

b: Adjust the grip to the area you wish and tighten the 2 screws.



8. The Crossbow comes with a parallel quiver mount. It can be mounted onto the left or right side of you crossbow.

Loosen the screws on the mounting bracket and attached to the picatinny rail under the barrel, in front of the forearm.

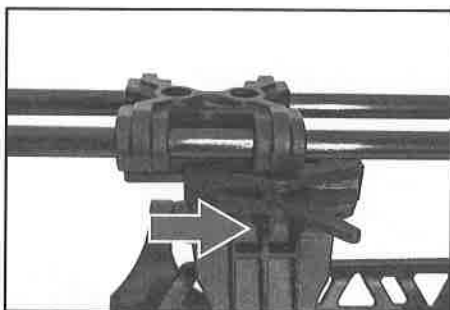

9. Slide the quiver onto the bracket, pushing it all the way to the top.



10. Close the latch as shown.
This will lock the quiver to the bracket.



11. Attach the sling stud to the front of the crossbow as shown. The sling stud is located within the sling packet.
May require pliers to fully tighten.



12. To attach the padded shoulder sling to the crossbow, loosen the thumb screw on the sling swivel. Locate it on the sling stud and retighten the thumb screw.



13. Align the scope mount with the slots on the weaver style sight base.

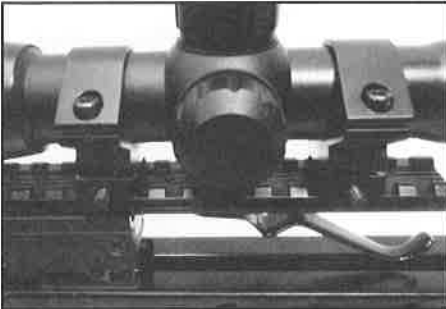

14. Slide in each of mounting brackets in the desired position on the weaver style sight base.



15. Tighten the locking nuts by hand or Allen key or screw driver if needed.

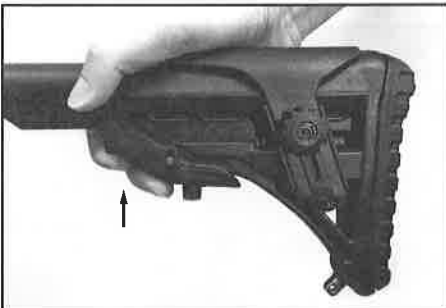

16. Adjusting the Stock Length

1. Press the lever on the bottom of the stock.
2. Slide the Stock from 0~5 to lengthen or shorten stock position.
3. Release the lever to lock into place.

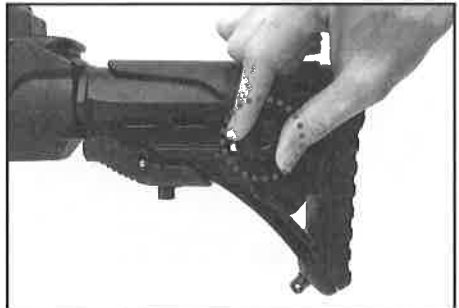

17. Loosen out the stud on both sides.



18. Tighten the stud after adjusting the cheek piece.



20. Before using, lubricate the string serving and rail. Failure to do so will result in the string serving burning and wearing out prematurely. We recommend apply the wax every 10 to 15 shots.

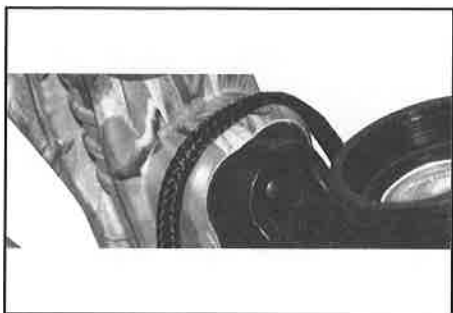

21. Before cocking, make sure the safety catch must be in the "Fire" position. Drape the middle of the rope over the groove in the stock located behind the trigger mechanism/scope.



19. Mark your string to ensure that you are cocking the bow in a consistent manner. Due to the high draw weight involved in cocking the bow, it is easy to cock the crossbow off center. Failure to cock the crossbow squarely will result in poor accuracy. Simply mark the string with a marker or other means visibly ensure the bow is being cocked properly.



22. Place the hooks onto the crossbow string on each side of the flight track/rail.

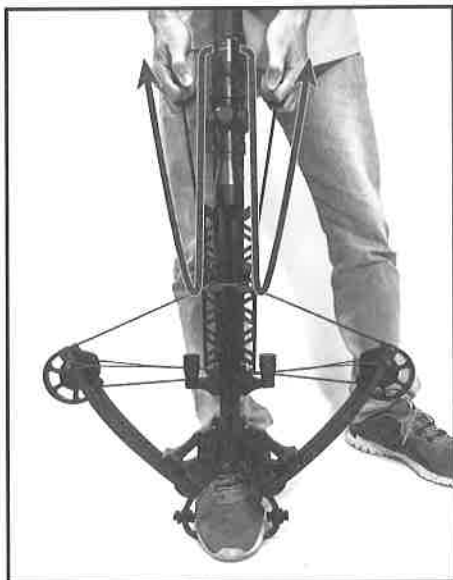

23. Place your foot into the stirrup. Pull both T-handles simultaneously, smoothly drawing the crossbow string back under the crossbolt retention spring and into the string opening in the trigger mechanism. (tension will keep cocking hooks against barrel if done properly). Continue drawing fully to the rear until the trigger safety moves to the " Safe " position. Relax the tension slightly to ensure the trigger latch has fully captured the crossbow string. The crossbow is now fully cocked, ready for loading. Remove the rope cocker before shooting.

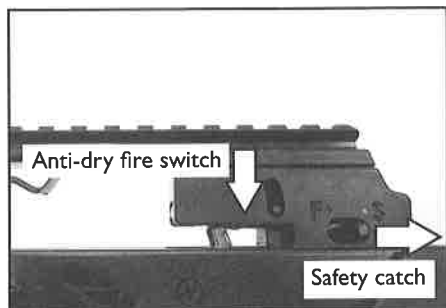

24. When you receive the crossbow, the Anti-dry fire switch is at " Middle " position , Safety catch is at " FIRE (Red dot) " position.

After cocking, the anti-dry fire switch will move from " Middle " position to the " Bottom " position, and the safety catch will move from FIRE (Red dot) to SAFE (Green dot) position.

After loading bolt, the anti-dry fire switch will move from " Bottom " position to " Top " position, and the safety catch will remain at SAFE (Green dot) position.

When you are ready to shoot, please move the safety catch from SAFE (Green dot) position to FIRE (Red dot) position, then pull the trigger. The bolt will fly out.

Please note " DO NOT AIM AT PEOPLE " or anything you do not intend to shoot.

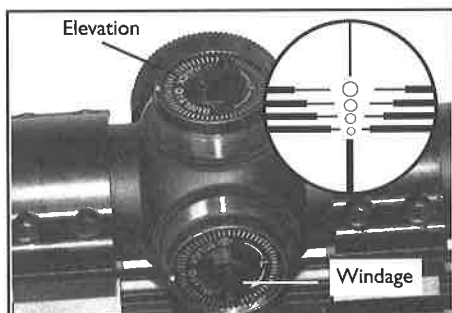

25. We suggest beginning to sight in your crossbow at no more than 10 yards to ensure that you are able to hit the target easily and to avoid loss or damage of your bolts. You will be sighting in the TOP CIRCLE on your scope for the shortest distance.

The other circles below the top one will offer you additional yardage sight points, the lower the circle the further the distance. These distances will depend on your initial yardage sighting of the top circle, and also depend on your bolt (bolt shaft length, size and weight of tip).

Windage adjustment knob:

Arrow striking right, adjust windage wheel CLOCKWISE

Arrow striking left, adjust windage wheel COUNTER-CLOCKWISE.

Elevation adjustment knob:

Arrow striking high, adjust elevation wheel CLOCKWISE.

Arrow striking low, adjust elevation wheel COUNTER-CLOCKWISE.